

Heavy Duty Wall Mount Bracket

Features

- 1.5" Diameter x 5.5" Mounting Surface
- 8" Standoff From Wall or Pole
- Heavy Zinc Plated Steel

Applications

- Antenna Mounting
- Surveillance Cameras
- Wireless Radio Mounting
- Lighting Applications



Description

The WMB-HD wall mount bracket provides a 1.5" diameter by 5.5" long pole to mount all kinds of pole mount radio equipment, antennas, camera equipment and misc equipment to a wall. It provides an 8" standoff from a wall or pole. Can be attached to a wall with screws or to a pole with screws or hose clamps.

Specifications

	WMB-HD
Material	0.078" Thick Zinc Plated Steel
Minimum Plating Thickness	0.0005" Zinc Plating
Customer Mounting Surface	1.5" diameter x 5.5" tall
Standoff From Wall	8"
Weight	1 lb

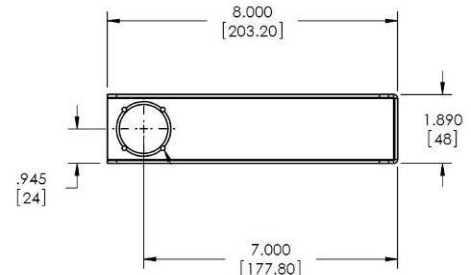
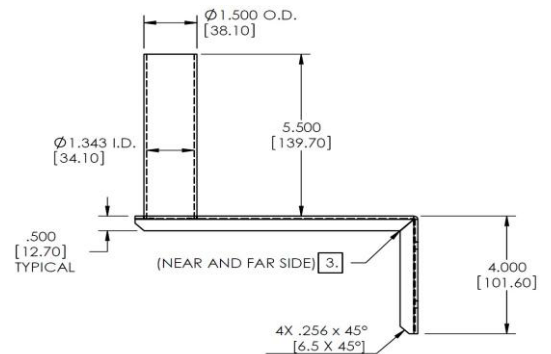

Notes:

All shipments F.O.B. Draper, UT 84020
 Tycon Power Systems WMB-HD carry a 2 year limited warranty

Ordering:

WMB -HD 1.5" diameter Heavy Duty Wall Mount Bracket